

# PIN PULLER 250N

## LOW-SHOCK NON-EXPLOSIVE PIN PULLER ACTUATORS

Pin Puller actuators are low-shock mechanical devices in which a pressure cartridge causes a pin or piston to retract inside the structure frame, usually against a side load. In the extended position, the pin or output shaft can be seen to be loaded by a compression spring. The pin remains firmly locked in this position due a mechanical components block stroke. Once actuated however, the actuator drives specific mechanical components releasing stroke and allowing the pin to retract under the force of the drive spring.

The actuator is resettable by manually moving the pin back into the extended position. It also incorporates a redundant SMA trigger capable of independently activating the device.

Pin pullers are used to hold-down and release of deployable parts such as solar panels, communication antennas, instrument cover doors, heat shields, scientific payload, etc.

ARQUIMEA's devices are ITAR free.

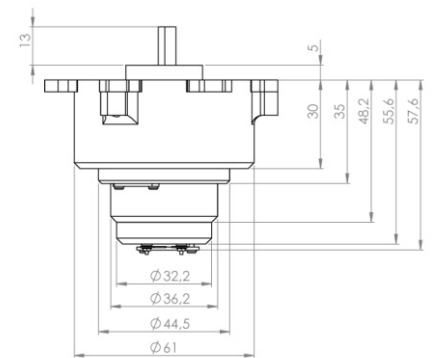
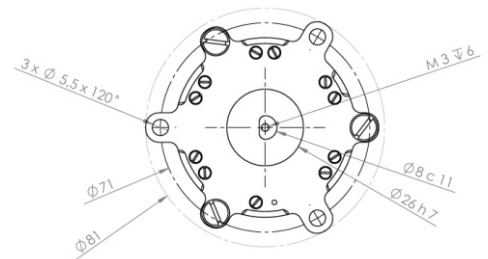

Part Number	ARQ.PLL.S01.251S.FM	ARQ.PLL.S01.251E.FM
Pull Force (min) [N]	250	250
Max. Side Load [N] (non actuating)	2,250	2,250
Max. Side Load [N] (during actuation)	450	450
Pull Stroke (min) [mm]	13	13
Operation Temp. [°C]	-50 to +70	-50 to +125
Non Activation Temp. [°C]	Pre-actuation -120 to +70	Pre-actuation -120 to +125
	Post-actuation -150 to +120	Post-actuation -150 to +150
Power Supply (max) [W] (*)	30 @ 4.1A and +23°C	128 @ 3.2A and +23°C
Activation Time [s] (**)	2.2 @ 4.1A and +23°C	3.5 @ 3.2A and +23°C
Resistance (Ω)	1.7 Ω ± 10%	12 Ω ± 10%
Life Cycles (min)	25	25
Envelope (Ø x L) [mm]	81 x 56.6	81 x 56.6
Mass [g]	194	194
Mechanical interface (customizable)	3 x M5	3 x M5
Electrical interface (customizable)	28 to 40 V	28 to 40 V

- Redundant SMA trigger (two independent triggers)
- Resettable by manually reset. Reset tool provided by ARQUIMEA
- Custom configurations available

(\*) depending on actuation time required and environmental temperature

(\*\*) depending on power supply and environmental temperature

### ENVIRONMENT REQUIREMENTS (on ground)

#### During storage:

Pressure: From vacuum to ambient

Temperature: 22°C ± 3°C

Relative humidity: <60%

#### During transportation:

Pressure: 970 to 1050 mbar

External temperatures: -40°C to +40°C

Relative humidity: <60%

### LIFETIME

ARQUIMEA's actuators meet their requirements after a maximum on-ground lifetime of 16 years including up to 12 years in storage. Device has been designed to be actuated and reset up to 25 times for Space applications (more than 100 cycle during test campaigns)

### Actuation time at various temperatures

#### Standard Temp

#### Extended Temp

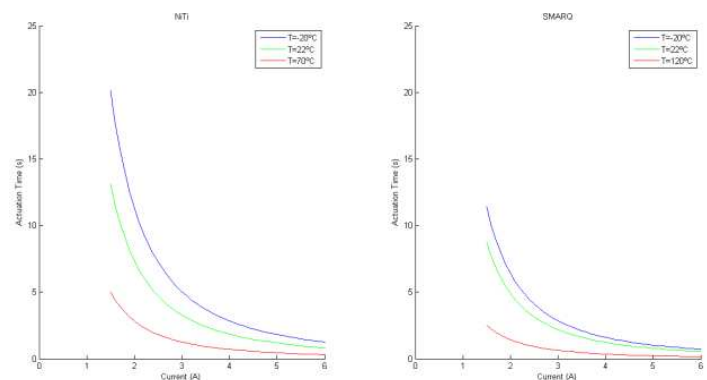

### ARQ\_DSH.ARQ.PLL.S01.251x.FM\_issue 01

### LEGAL WARNING AND EXCLUSION OF LIABILITY

The information herein contained is subject to variation depending on the use and environmental conditions.

Under this document, the Company assumes no obligation towards third parties, liability or guarantee whatsoever.